

TOP COVER

BOTTOM COVER

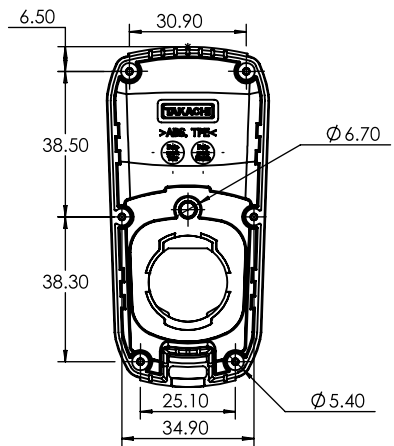
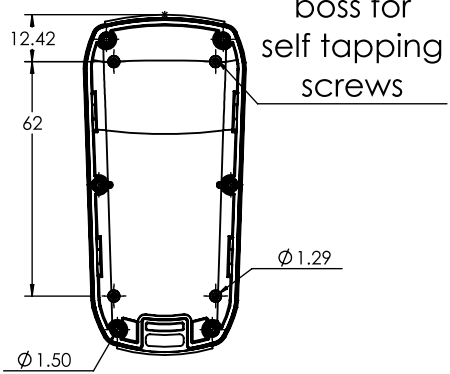

TECHINCAL DATA	
PROTECTION	IP67
OPERATING TEMPERATURE	-10°C ~ +50°C
RECOMMENDED TORQUE	0.06 ~ 0.08Nm
BATTERY COMPARTMENT TYPE	CR2032 x1

<p>CAMDENBOSS JAMES CARTER RD, MILDENHALL, SUFFOLK. IP28 7DE TEL: 01638 716101 FAX: 01638 716554 EMAIL: Sales@CamdenBoss.com WEB: www.CamdenBoss.com</p>				UNLESS OTHERWISE SPECIFIED: DIMENSIONS ARE IN MILLIMETERS		DO NOT SCALE DRAWING		REVISION. ○	
				GENERAL TOLERANCES +/- 0.2		TITLE: DIMENSIONED GENERAL DRAWING FOR 93 SERIES - IP67 PORTABLE CASE SIZE 2 BATTERY COMPARTMENT			
FINISH. LIGHT SPARK				MATERIAL. BODY - ANS UL 94 - HB GASKET - SILICONE		DWG NO. CHH932BBB		A4	
DRAWN	IAN PAGANO	I.P.	18/01/17	PROJECTION.		SCALE: 1:2		SHEET 1 OF 1	
CHK'D	Alex G.	A.G.	20/09/17						