

THIS DRAWING IS THE PROPERTY OF CAMDENBOSS AND MUST NOT BE COPIED WITHOUT PRIOR PERMISSION

NOTE:

X Spacing: 153.4 mm

Y Spacing: 60.4 mm

TABS TOP & BOTTOM

!! KEEP IN VERTICAL STRIPS FOR BENDING CUTS !!

Carbon Fibre

APPROVED

PART NUMBER	3mm THK MATERIAL & COLOUR
CBRPP-BA-BLK	HIPS HB, GLOSS/MATT BLACK
CBRPP-BA-WHT	HIPS HB, GLOSS/MATT WHITE
CBRPP-BA-CAR	ABS CAPPED, CARBON FIBRE
CBRPP-BA-CLR	PETG, TRANSPARENT

FOR CBRPP_AA-CLR BENDING CUTS TO BE DONE ON CNC !!

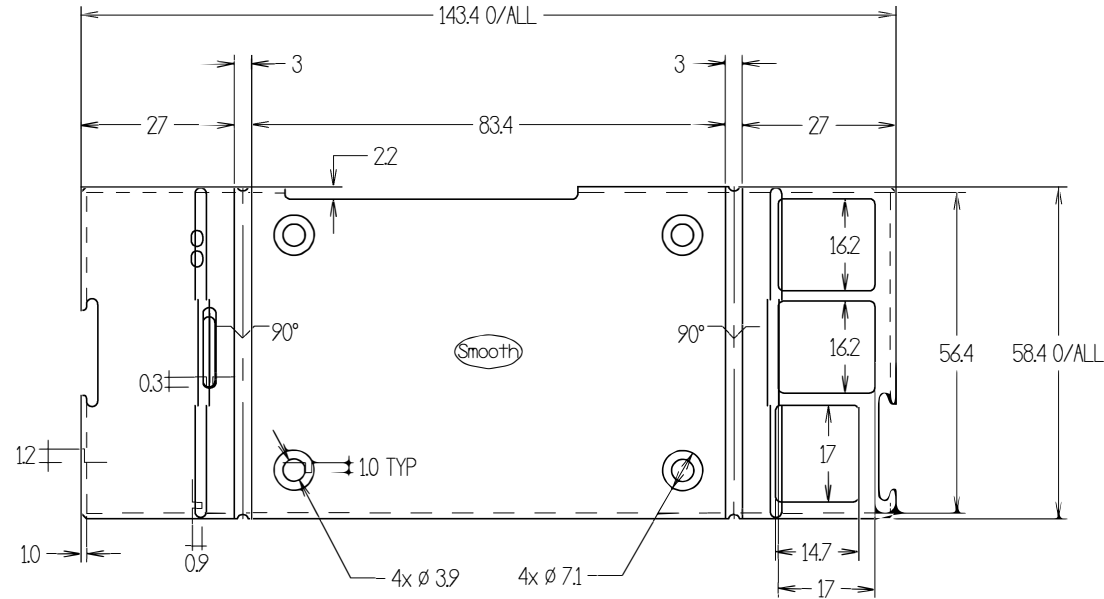

BA × 1

!! ENSURE PROTECTIVE FILM IS KEPT ON AT ALL TIMES !!

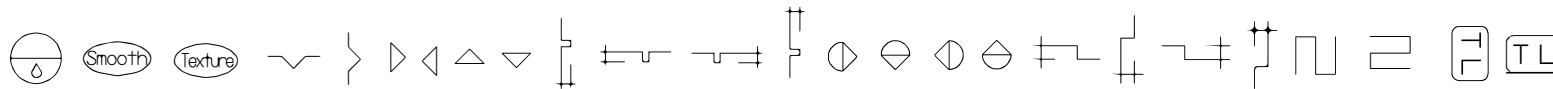

TOOL TABLE		
No.	DESCRIPTION	ORDER
1	6mm STRAIGHT SINGLE FLUTE	-
2	6mm CSK / CHAMFER	-
3		-
4	R2 FACET	-
5		-
6	3mm STRAIGHT SINGLE FLUTE	-
7	2mm STRAIGHT SINGLE FLUTE	1
8		-
9	ENGRAVING TOOL	-
10	1mm STRAIGHT SINGLE FLUTE	-

-	-	-	-	 CAMDENBOSS JAMES CARTER RD, MILDENHALL, SUFFOLK, IP28 7DE TEL: 01638 716101 FAX: 01638 716554 EMAIL: Sales@CamdenBoss.com WEB: www.CamdenBoss.com	DRAWN MATTHEW WALLACE CHECKED D.SMALLEY STRUCT. TEXTURED DOWN MTL. SEE TABLE COLOUR SEE TABLE NO GIVEN SCALE - IF IN DOUBT ASK	PROJECT RASPBERRY PI B+ ENCLOSURE TITLE BOTTOM U-SHELL DATE 15/07/14 S/A. B-BASE CSTM. CAMDENBOSS P.N. CBRPP_BA	ORDER OF PROD. 1 TIME FOR 1	MILLING 1 BREAK FLASHING 2/4 REVERSE MILLING TONGUE 6 CHAMFER/RAD BENDING CUT 3 GROOVE SAW-CLIP COUNTER SINK INSERT SCREEN PRINT BENDING 5 GLUE RFI SHIELDING PAINTING
0	FIRST ISSUE	MJW	15/07/14		ALL DIMENSION IN mm TO ±0.2mm TOLERANCE UNLESS OTHERWISE STATED			
REV.	MODIFICATION	BY	DATE					

APPROVED

PACKING INSTRUCTIONS:

1. SHRINK-WRAP INDIVIDUALLY AT !! 60° !!
2. PLACE A DISTRIBUTORS LABEL ON EACH SHRINK-WRAPPED ENCLOSURE.
3. REFER TO PICKING SLIP FOR PACKING INSTRUCTIONS. IF THERE ARE NO INSTRUCTIONS ON THE PICKING SLIP PLEASE REFER TO STEP 4-6.
4. IN A LARGE CAMDENBOSS BOX, PLACE A LAYER OF BUBBLE WRAP AT THE BOTTOM OF THE BOX.
5. PLACE 200 INDIVIDUALLY SHRINK-WRAPPED PARTS IN COLOURS, PLACING A PIECE OF CARD INBETWEEN EACH COLOUR.
6. PLACE A LAYER OF BUBBLE WRAP AT THE TOP OF THE BOX.

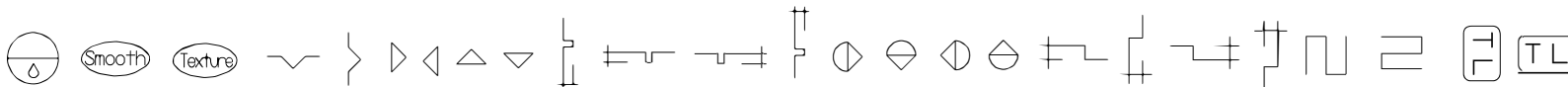

TOOL TABLE		
No.	DESCRIPTION	ORDER
1	6mm STRAIGHT SINGLE FLUTE	-
2	6mm CSK / CHAMFER	-
3		-
4	R2 FACET	-
5		-
6	3mm STRAIGHT SINGLE FLUTE	-
7	2mm STRAIGHT SINGLE FLUTE	-
8		-
9	ENGRAVING TOOL	-
10	1mm STRAIGHT SINGLE FLUTE	-

-	-	-	-	 CAMDENBOSS JAMES CARTER RD, MILDENHALL, SUFFOLK, IP28 7DE TEL: 01638 716101 FAX: 01638 716554 EMAIL: Sales@CamdenBoss.com WEB: www.CamdenBoss.com	DRAWN MATTHEW WALLACE CHECKED D.SMALLEY STRUCT. - MTL. - COLOUR -	PROJECT RASPBERRY PI B+ ENCLOSURE TITLE PACKING INSTRUCTIONS DATE 28/07/14 S/A. X-PACKING CSTM. CAMDENBOSS P.N. CBRPP_BA_XA	5 6 7 8 9 10	- - - - - - - -							
A	ECR-000-350	JPG	21/04/15		ALL DIMENSION IN mm TO ±0.2mm TOLERANCE UNLESS OTHERWISE STATED	NO GIVEN SCALE - IF IN DOUBT ASK									
0	FIRST ISSUE	MJW	28/07/14												
REV.	MODIFICATION	BY	DATE												
ORDER OF PROD.	MILLING	BREAK FLASHING	REVERSE MILLING	TONGUE	CHAMFER/RAD	BENDING CUT	GROOVE	SAW-CLIP	COUNTER SINK	INSERT	SCREEN PRINT	BENDING	GLUE	RFI SHIELDING	PAINTING

APPROVED

PROTOTYPE / PRODUCTION NOTES:

!! TO BE PASSED BACK TO DESIGN !!

EXAMPLE:

1. DRAWING _AA (TOP U-SHELL) CHAMFER SYMBOL MISSING.

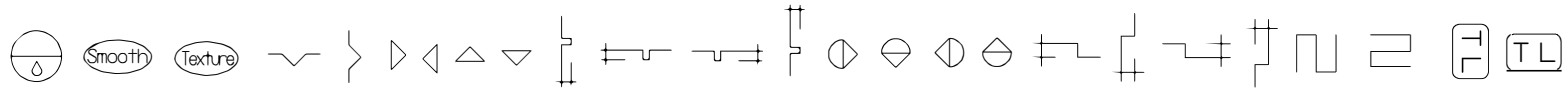

TOOL TABLE		
No.	DESCRIPTION	ORDER
1	6mm STRAIGHT SINGLE FLUTE	-
2	6mm CSK / CHAMFER	-
3		-
4	R2 FACET	-
5		-
6	3mm STRAIGHT SINGLE FLUTE	-
7	2mm STRAIGHT SINGLE FLUTE	-
8		-
9	ENGRAVING TOOL	-
10	1mm STRAIGHT SINGLE FLUTE	-

-	-	-	-	<p>CAMDENBOSS JAMES CARTER RD, MILDENHALL, SUFFOLK IP28 7DE TEL: 01638 716501 FAX: 01638 716554 EMAIL: Sales@CamdenBoss.com WEB: www.CamdenBoss.com</p>	DRAWN	MATTHEW WALLACE	PROJECT	RASPBERRY PI B+ ENCLOSURE	5						
-	-	-	-		CHECKED	-	TITLE	PROTOTYPE / PRODUCTION NOTES	6	3mm STRAIGHT SINGLE FLUTE	-				
-	-	-	-		STRUCT.	-	DATE	15/07/14	7	2mm STRAIGHT SINGLE FLUTE	-				
-	-	-	-		MTL.	-	S/A.	N-NOTES	8		-				
0	FIRST ISSUE	MJW	15/07/14		COLOUR	-	CSTM.	CAMDENBOSS	9	ENGRAVING TOOL	-				
REV.	MODIFICATION	BY	DATE	ALL DIMENSION IN mm TO ±0.2mm TOLERANCE UNLESS OTHERWISE STATED		P.N.	CBRPP_NA	10	1mm STRAIGHT SINGLE FLUTE	-					
ORDER OF PROD.	MILLING	BREAK FLASHING	REVERSE MILLING	TONGUE	CHAMFER/RAD	BENDING CUT	GROOVE	SAW-CLIP	COUNTER SINK	INSERT	SCREEN PRINT	BENDING	GLUE TIME PER ENCLOSURE	RFI SHIELDING	PAINTING
TIME FOR 1															