

ASSEMBLY

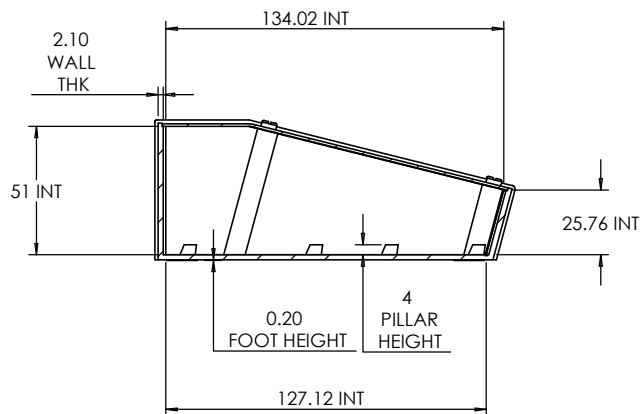

SECTION A-A

LID

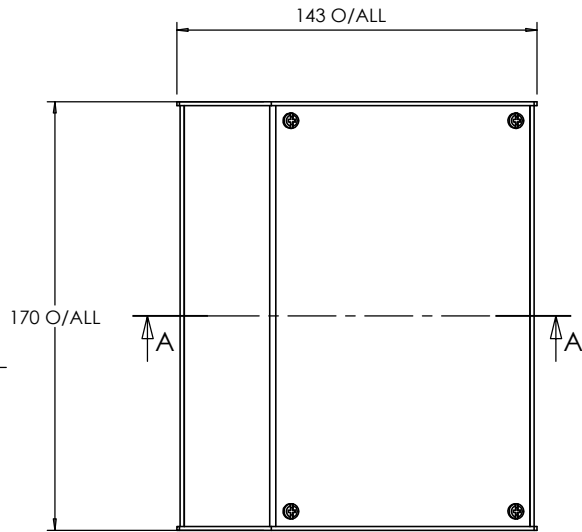
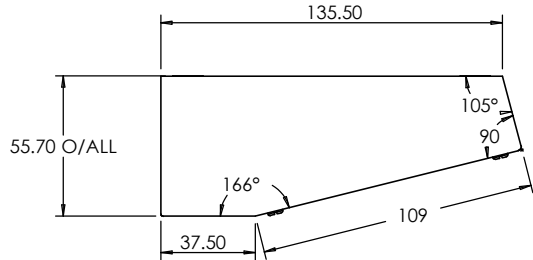
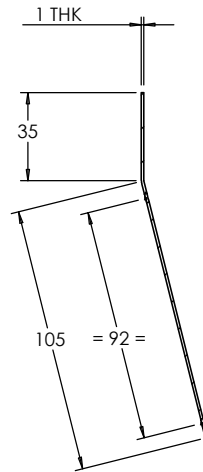
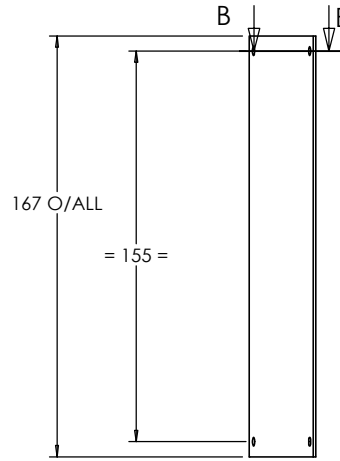

SECTION B-B

**ISO VIEW
1:5**

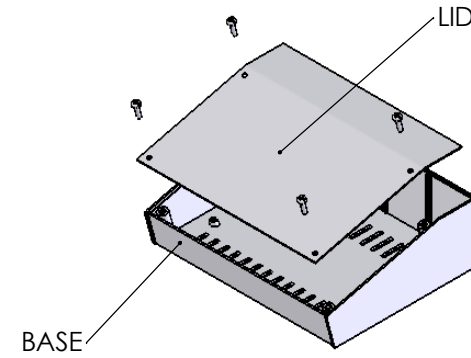

BASE

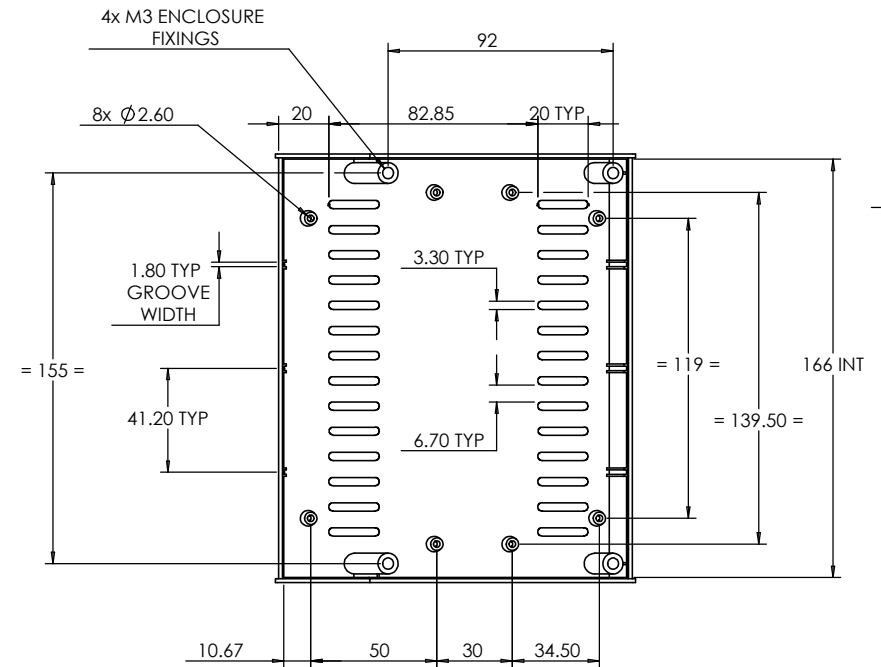

<p>CAMDENBOSS JAMES CARTER RD, MILDENHALL, SUFFOLK. IP28 7DE TEL: 01638 716101 FAX: 01638 716554 EMAIL: Sales@CamdenBoss.com WEB: www.CamdenBoss.com</p>				UNLESS OTHERWISE SPECIFIED: DIMENSIONS ARE IN MILLIMETERS		DO NOT SCALE DRAWING		REVISION. 0	
				FINISH: SMOOTH		TITLE: GENERAL ASSEMBLY DRG FOR 6000 SERIES			
DRAWN SUBKHANKULOVA		SIGNED LS	DATE 16/07/09	MATERIAL: ABS & ALUMINIUM		DWG NO. 6006		A4	
CHK'D STUART HARDINGE		SIGNED SJH	DATE 16/07/09	PROJECTION. 		SCALE: 1:2		SHEET 1 OF 1	