

SECTION A-A

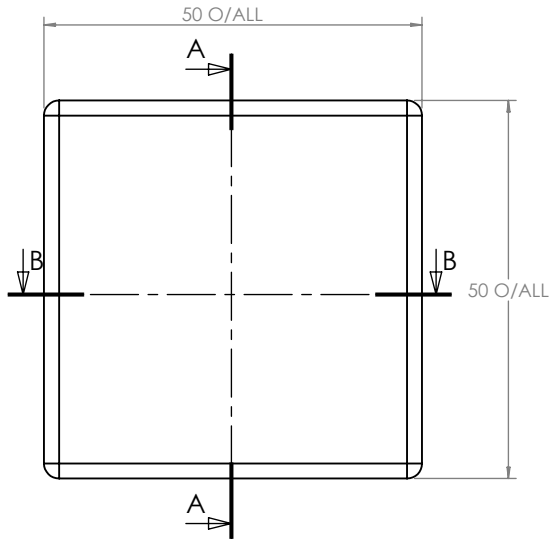

SECTION B-B

ASSEMBLY

ISO VIEW
1:2

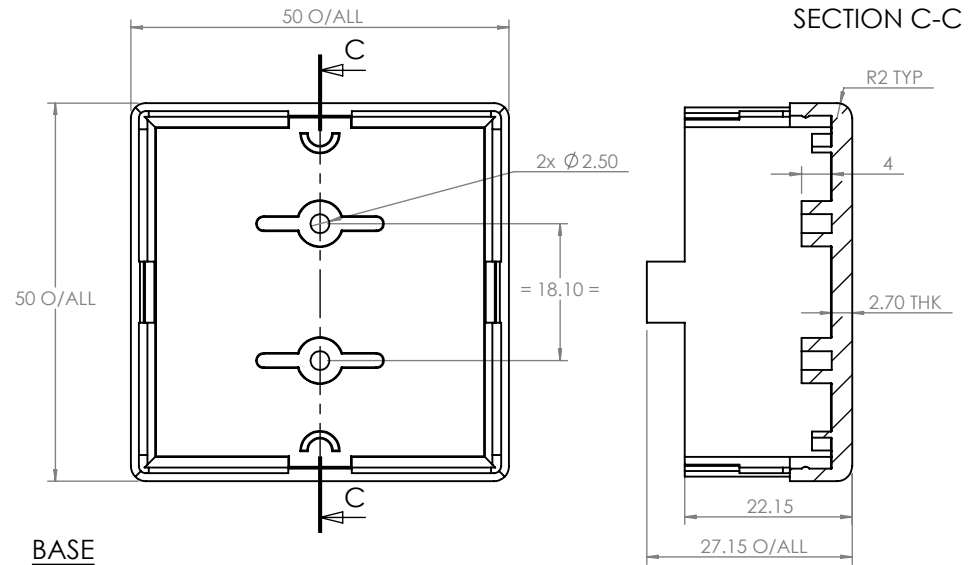
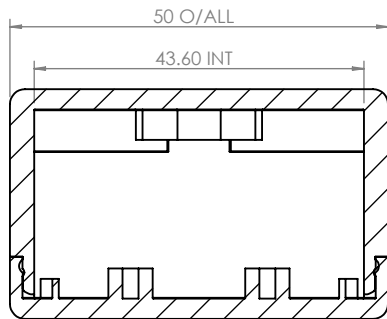
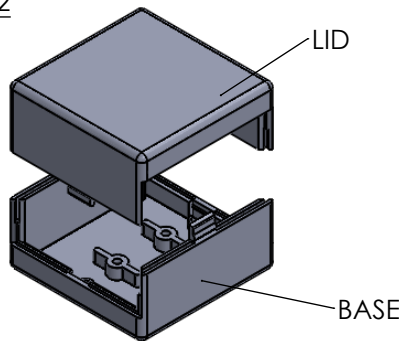

BASE

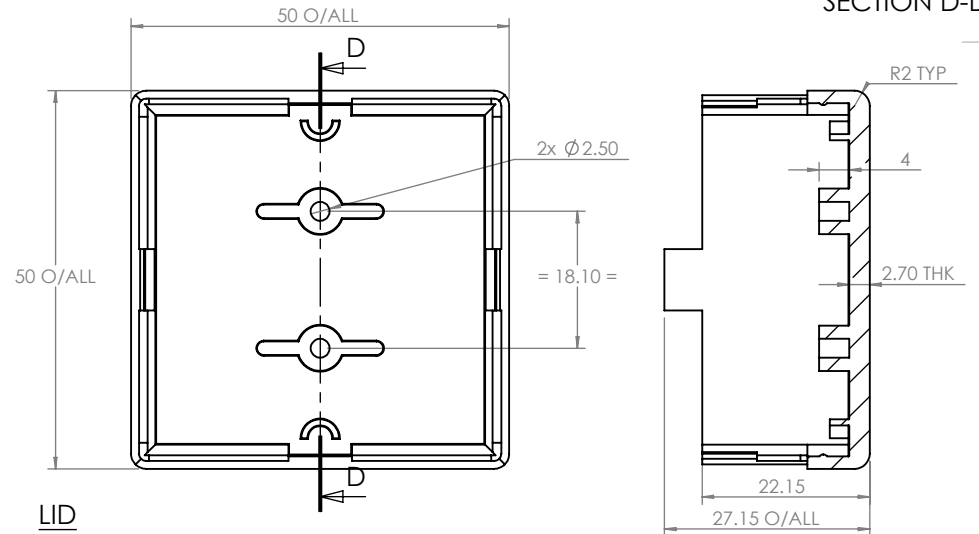

LID

 CAMDENBOSS JAMES CARTER RD, MILDENHALL, SUFFOLK. IP28 7DE TEL: 01638 716101 FAX: 01638 716554 EMAIL: Sales@CamdenBoss.com WEB: www.CamdenBoss.com		UNLESS OTHERWISE SPECIFIED: DIMENSIONS ARE IN MILLIMETERS	DO NOT SCALE DRAWING	REVISION. 0		
		GENERAL TOLERANCES +/- 0.2	TITLE: GENERAL ASSEMBLY DRAWING FOR 300 SERIES			
DRAWN	NAME	SIGNED	DATE	MATERIAL.	DWG NO.	300-5030 A4
CHKD	MATTHEW WALLACE	MJW	29/11/11	ABS	300-5030	
				FINISH. SMOOTH	SCALE. 1 : 1	SHEET 1 OF 1
				PROJECTION. 